

PICO

UV DIGITAL INKJET PRESSES

www.dantex.com

DANTEX
GROUP

PICO TECHNOLOGY: EVOLVED & UNBEATABLE



Dantex Group has served the global label print and packaging industry for over 50 years. Our product portfolio includes a complete range of letterpress and flexographic consumables and equipment, as well as our Pico Range of UV Digital Label presses. Dantex builds long-term customer relationships by bringing quality products and cost-effective solutions to the market.

Dantex's wealth of industry knowledge enables us to manufacture our own products and thoroughly understand our customers' requirements.

Our increased presence in the global digital print market has led to the expansion of the Dantex Digital Division, which is based at our state-of-the-art production and Research & Development facility in the UK. The impressive Pico range of Digital UV Inkjet Presses offers four different modular print platforms from entry level to full hybrid, 8-colour, high-speed models.

The Pico Range: PicoColour HD 1200, PicoJet 1200, PicoJet 1200i, and our flagship PicoJet 1200s high-speed model. Dantex can offer a solution to suit your individual production requirements.

- Improve profitability on every label.
- Ultimate flexibility and highest print speeds available.
- Vivid, photo-realistic images and SuperWhite.
- Industry-leading software.
- No minimum print quantity.
- No speciality substrates or pre-coating required.
- Hybrid finishing offers wide range of embellishments and finishing.
- Super-fast job turnaround.
- Built to the highest quality industry standards.

Whether you're considering digital for short run, long run, or both, with **Pico by Dantex** you can have a highly productive, affordable label printing solution to meet your demanding production requirements, both now and in the future. **No minimum quantity, no speciality substrates, no pre-coating and super-fast turnaround - with superb quality results.**

ONE: SUPERWHITE & DECOTACTILE

SUPERWHITE® & DECOTACTILE SINGLE PASS, HIGH OPACITY

PicoJet features **SuperWhite®** technology which is capable of producing a white ink opacity up to 92% in a single pass, making it the highest opacity inkjet white available on the market, similar to that achieved printing with flat or rotary screen technology. This is achieved without any loss in print speed up to 75m (250ft)/min.

SuperWhite led to the development of **DecoTactile**, which is used to create a range of high-quality embellishments to give enhanced detail and vibrancy, such as raised tactile finishes and textures. High-build capabilities to give a digitally embossed effect to chosen parts of the design, offering luxury finishes at low cost.

- Highest opacity inkjet white available.
- Single pass.
- Up to 92% opacity.
- High quality bright white.
- Defined stable dot shape.
- No colour inter-mixing.
- Luxury finishes.
- DecoTactile print effects.
- No loss of speed.



Dantex's specially formulated white ink is instrumental to the quality of SuperWhite and DecoTactile finishes. Our curing technology stops the ink droplet from spreading and gives a defined dot shape, and superior quality printing of solid areas. This additionally improves fine white text, linework and reversed-out solids with no trapping or reticulation issues.



TWO: ORANGE VIOLET & GREEN

ORANGE, VIOLET & GREEN ADDITIONAL COLOURS

Pico now offers 3 new additional colour options: Orange, Violet & Green.

Our press range already achieves above 91% of the Pantone range, but is now capable of an extended colour gamut - 96% pantone colours at a Delta E of 3 and below.

Quality and accuracy are further enhanced in addition to greater colour matching capabilities. Extended colour options offer photo-realistic imagery with no loss of speed. Dantex's bespoke inkset allows our pinning technology to perform to its very best without needing to coat or prime material.

- 3 New additional colour options.
- 96% colour gamut.
- No loss of speed.
- Greater print quality.
- Excellent colour accuracy.
- Photo-realistic images.
- Future-proofing additional colours.
- Dantex formulated inks.
- Bespoke colour profiling.



Dantex has partnered with Industry leading software developers to maximize the efficiency and quality of the extended colour options. The extended colour range will help you to produce truly exquisite photo realistic labels day in, day out, with scientifically accurate pantones.

(More info in section 8)



THREE: LED CURE & PINNING

LED CURE INTER-COLOUR PINNING/FINAL CURE

LED UV curing is ideal for the UV Inkjet market. Dantex's innovative inter-colour pinning technology places pinning lamps between colours to stabilize the ink, reducing the spread of the ink on synthetic substrates or diving in of ink on absorbent materials, such as uncoated papers. Stabilizing the ink also allows a good surface for the following ink to sit onto and eliminates the mixing of wet inks, which can affect the target colour the operator is looking to achieve. By increasing and decreasing the power of the pinning lamps it is easy to adjust the flow, the gloss level of the inks, and the visual finish of the label. This is not achievable with some inkjet machines available in the narrow web market.

With final cure LED lamps, the intensity output of the LED lamp is better suited for through cure of thick ink films. Press speeds of 75m/min are achievable with the correct ink/LED combination. The lamps only turn on when the machine is printing and can be turned off in areas where there is no print present, for example when a narrower web is being used.

A UV LED lamp's life is around 20,000 hours, whereas the life of a traditional lamp is between 1000-2000 hours. With LED curing systems there is no ozone emitted from the lamp, meaning a safer environment for press operators. UV LED lamps emit minimal heat, so running more sensitive substrates is achievable. Because there is little heat and no ozone present, air ducting is not required resulting in a better working environment.

- Control of dot gain.
- Intensity (pinning) control.
- Reduced ink spread.
- Low voltage.
- High colour accuracy.
- Superb colour consistency.
- Low heat impact.
- Eco friendly.
- Fully adjustable.



UV cured ink has long been attractive to printers because of its near-instant drying and excellent adhesion properties to a wide range of substrates. In addition, it is more environmentally beneficial than other ink formulations, especially due to its low volatile organic compounds (VOC).

FOUR: INLINE FINISHING

INLINE FINISHING FROM DANTEX

Dantex's wealth of label industry knowledge and understanding of our customers' requirements enables us to manufacture our products to suit particular production requirements.

Every Pico press in the range is available as a reel-to-reel printing platform allowing you to utilise existing offline finishing systems, or they can be designed in a variety of hybrid configurations to maximize output and take your production capabilities to the next level.

Inline flexo options offer a multitude of embellishments from spot and flood coat varnishing to spot colours and cold foiling. Self-wound and pre-wound laminates can be applied, and the full rotary die station, along with edge trim and slit modules, means you can have applicator-ready labels coming off the PicoJet every day of the week.

- Pre and Post print flexo stations.
- LED and ARC cure options.
- Full rotary die station.
- Easy load die trolley system.
- No need for lifting equipment.
- Pre and self wound lamination.
- Edge trim.
- Razor and shear slit options.
- Cold foiling and embellishments.

Our operator friendly presses include all the features you need on a daily basis to produce a wide range of bespoke labels at high speeds. Achievable finishes include soft and rough touch spot varnish, gloss and matte finishes, tactile effects, foiling, spot colours, self and pre-wound laminates and the ability to run on pre-printed materials - all finished with inline die cutting and slitting.

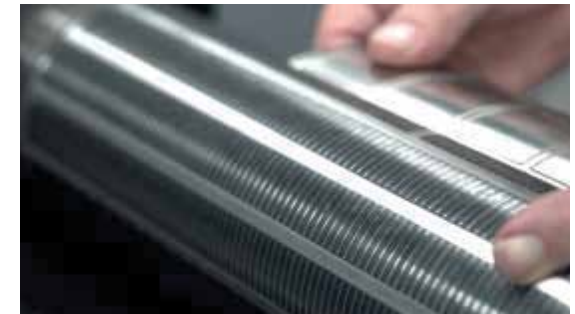

PICOLOUR HD 1200i



- SYSTEM OPTIONS
- Additional Colour Station
- SuperWhite® Station
- Corona
- Variable Data
- Mark Sensor
- Reel Lifter

- FINISHING OPTIONS
- Die Cutting
- Slit/Edge (Razor)
- Lamination

Dimensions (LxDxH)
 515cm x 170cm x 205cm / 202.76" x 66.93" x 80.71"
+ Finishing (LxDxH)
 615cm x 170cm x 205cm / 242.13" x 66.93" x 80.71"
Print Width / Speed
 254mm / 10" / 50m / 164' per minute
Substrate Thickness
 50 - 300µm (*Thickness dependent on material properties*)
Available Colours
 CMYK / WHITE / + 1 ADDITIONAL COLOUR

PICOJET HYBRID



PICOJET is built on a modular platform, so is available as a reel to reel press on PJ1200/PJ1200i/PJ1200S or as a bespoke hybrid system: allowing the incorporation of features such as Die Cutting and Flexo Station options. It can also be custom configured in a variety of base and additional colour stations.

- DIE STATION OPTIONS
- Razor Slit
- Shear Slit
- RD Scorer (Edge Trim)
- Lamination
- Nip & Peel (*only with rewind*)
- Die Loading Trolley
- Die Cylinder Bench
- Video Inspection System

- FLEXO STATION OPTIONS
- LED Curing
- Mercury Arc Curing
- Cold Foil

PICOJET 1200/1200i/1200S



- SYSTEM OPTIONS
- Additional Colour Stations
- Corona
- Variable Data
- Mark Sensor

- SuperWhite® Station
- Chilled Roller
- Reel Lifter

Dimensions (LxDxH)
 535cm x 193cm x 205cm / 210.63" x 75.99" x 80.71"
Print Width
 254mm / 10" (PJ1200), 330mm / 13" (PJ1200i/PJ1200S)
Print Speed
 50m / 164' per minute (PJ1200/PJ1200i), 75m / 250' per minute (PJ1200S)
Substrate Thickness
 50 - 300µm (*Thickness dependent on material properties*)
Available Colours
 CMYK / WHITE / ORANGE / GREEN / VIOLET

HYBRID FEATURES & OPTIONS

- | | | |
|--|--|---|
| 1 Unwind with automatic end of reel detection. | 6 32" machine operation HMI (PicoCenta) | 11 Cold foiling/lamination. |
| 2 Web tracking system. | 7 32" control centre (PicoPilot) | 12 Full rotary die cutting. |
| 3 Web cleaner. | 8 Full LED final cure. | 13 Self-wound lamination. |
| 4 Automatic splice detection. | 9 MADE IN BRITAIN. | 14 Edge trim/shear or razor slit. |
| 5 Corona unit. | 10 Flexo station with LED or Mercury arc curing. | 15 Rewind with tension compensation technology. |

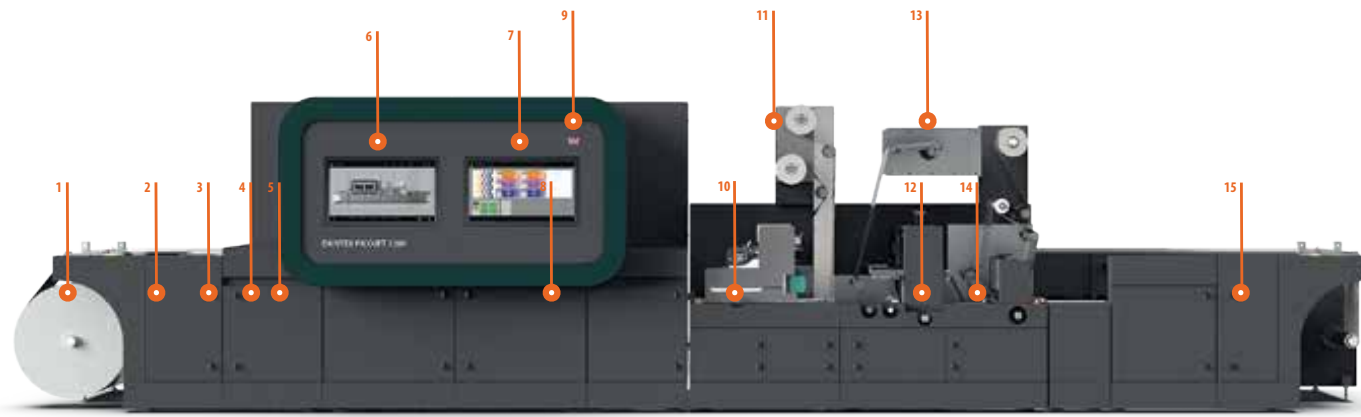

FIVE: COLOUR MANAGEMENT

COLOUR MANAGEMENT OPTIMAL PRINT QUALITY

We have strengthened Pico's software capabilities with the introduction of GIS (Global Inkjet Systems) & Esko's turnkey software solution. Esko's DFE (Digital Front-end) together with our print head technology enhances digital print for packaging making this the complete solution from print job creation to the optimisation of print quality through precise print head control.

Esko DFE software is easy to use and efficient, and features controlled systems, which control the flow of jobs through the Esko DFE components and stores parameters and configurations. Combined with GIS fast screening technologies and GIS Atlas IQ® Tools for image quality control with missing nozzle and print head density compensations, resulting in a seamless end-to-end solution.

- Esko's DFE (Digital Front-end)
- Easy to use and efficient.
- Precise print head control.
- Controlled job flow.
- Stores parameters & configurations.
- Edit Pantones.
- Create bespoke colours.
- Easy use step and repeat function.
- Full colour VDP.



Esko's DFE software allows the user to see the process colour values of any given pantone, which can be altered by as little as 0.1%. These values can be used to generate a colour chart which highlights many different iterations of the same pantone allowing the user to either select the lowest DE, or generate a customer approved bespoke colour.



SIX: RICOH HEADS

RICOH PRINT HEADS CLIMATE-CONTROLLED ELECTRONICS

Dantex Pico range uses Ricoh next generation print heads, which give an outstanding print result at high speeds. The Ricoh print heads produce an effective dpi of 1200 x 1200, producing truly striking photo-realistic prints to suit all areas and applications of the label and packaging market.

Dantex's flagship press, PicoJet 1200S, is capable of printing at speeds of up to 75m/min, therefore the print heads must jet quickly and efficiently in order to produce the same quality label achieved at 20m/min. In order to ensure our print head technology is running at 100% output at any speed, Dantex's engineers have developed a climate-controlled electronics system to ensure there is no over-heating or requirement for extraction fans; this keeps the print environment as clean and energy efficient as possible.

- Guaranteed quality.
- 100% defect-free nozzle technology.
- 2.5pl minimum drop size.
- 1200dpi Effective Resolution.
- Climate-controlled electronics.
- Low contaminate print zone.
- No electronic over heating.
- High Density solids.
- Unbeatable reliability.



Ricoh heads are manufactured with a high durability stainless steel housing giving outstanding reliability and stability at high speeds. With 1280 nozzles configured in 4 x 150dpi rows, this head achieves superb photo-realistic images with an effective resolution of 1200 x 1200 dpi. The print head's straightforward alignment method allows high-precision positioning and registration.



SEVEN: WASTE REDUCTION

WASTE REDUCTION FROM DANTEX

Dantex prides itself on being a green company; we are pioneers of water washable plates and processing, offering an environmentally-friendly alternative to solvent plate making. It is one of our core beliefs that we as a company have a responsibility to protect the environment and this philosophy has been integrated into the design and build of our range of Pico digital presses.

Pico offers a number of waste reduction features as standard; automatic splice detection ensures that the print heads are protected if there is a splice or mill join in the material by raising the print deck and letting a minimal amount of material through before print continuation. Reverse function allows the reversing of material to the previous job's final print before continuing to the next job, giving virtually zero wasted material. Material profiling allows registration settings to be saved giving a quick, efficient material change with minimal set up, saving time and material.

- Automatic Splice Detection.
- Substrate reverse function.
- Automatic end of reel detection.
- Quick register adjustment.
- Pre-stored material settings.
- Ink saving profiles.
- 100% ink yield.
- Knight Guard software.
- Change ink on the run.



Dantex has developed ink saving colour profiles to use the bare minimum amount of ink necessary to produce excellent quality work. Our Knight Guard software keeps the print heads active and optimized without the need for constant purging, and our proprietary inks are supplied and dispensed in a way that ensure you can use every last drop.



EIGHT: MADE IN BRITAIN

MADE IN BRITAIN MANUFACTURING EXCELLENCE

Dantex is extremely proud to have passed a stringent 150 point requirements list which guarantees that our manufacturing supply chain is 'truly British'. Only those products that pass this test are permitted to carry the MADE IN BRITAIN mark. Being the ultimate mark of British provenance, the Made in Britain accreditation is seen as an international seal of excellence domestically and across the world.

On account of its rapid growth, our digital division recently moved to a new 22,000 square foot manufacturing site in the UK. From this facility, our digital division's highly skilled workforce undertakes research and development, design, assembly, build and shipping; thereby providing customers with the benefits of a closeness in British manufacturing and engineering to the very highest standards.

- Guaranteed quality.
- Reliable local supply chain.
- Highly skilled workers.
- High quality standards.
- New manufacturing facility.
- Investing in the future.
- Rapid growth.
- In house Research & Development.
- MADE IN BRITAIN.



MANUFACTURED IN THE UK

Pico Digital Presses are manufactured in our new and much larger facility in the UK. Our main demonstration center is also located in the UK and has been fitted with the latest in remote technologies so we can provide remote or live demonstrations for customers from all over the world.



NINE:
GET
IN TOUCH

DANTEX GROUP

A TRULY GLOBAL PRESENCE

Dantex has been in the print and packaging for over 50 years, in this time we have built a reputation as one of the leading suppliers of printing equipment and consumables in the world. No matter where your company is based we have a subsidiary or distributor who are more than happy to help you with your digital printing needs. Please visit DANTEX.COM to register your interest and one of our highly-trained staff will contact you as soon as possible.

We thank you for your interest in our company and products and look forward to hearing from you soon.

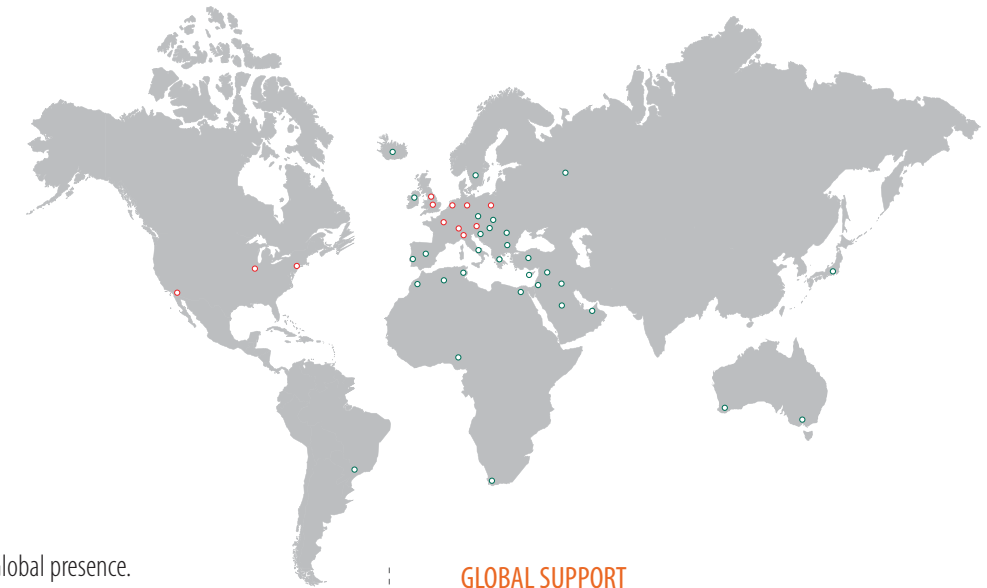

- Global presence.
- 2 Manufacturing sites in the UK.
- UK, US and German warehousing.
- Global distribution network.
- Sales and technical teams.
- Unbeatable customer service.
- Highly trained engineers and technicians.
- European demonstration facilities.
- Multilingual support.

GLOBAL SUPPORT

Pico Digital Presses are manufactured in our facility in the UK and we have customer demonstration facilities in the UK and Europe. Our warehousing is located in the UK, US and Germany enabling us to provide quick and efficient technical support, as well as parts and goods shipment.