

www.dantex.com

PICO *DRS*

UV DIGITAL INKJET PRESSES

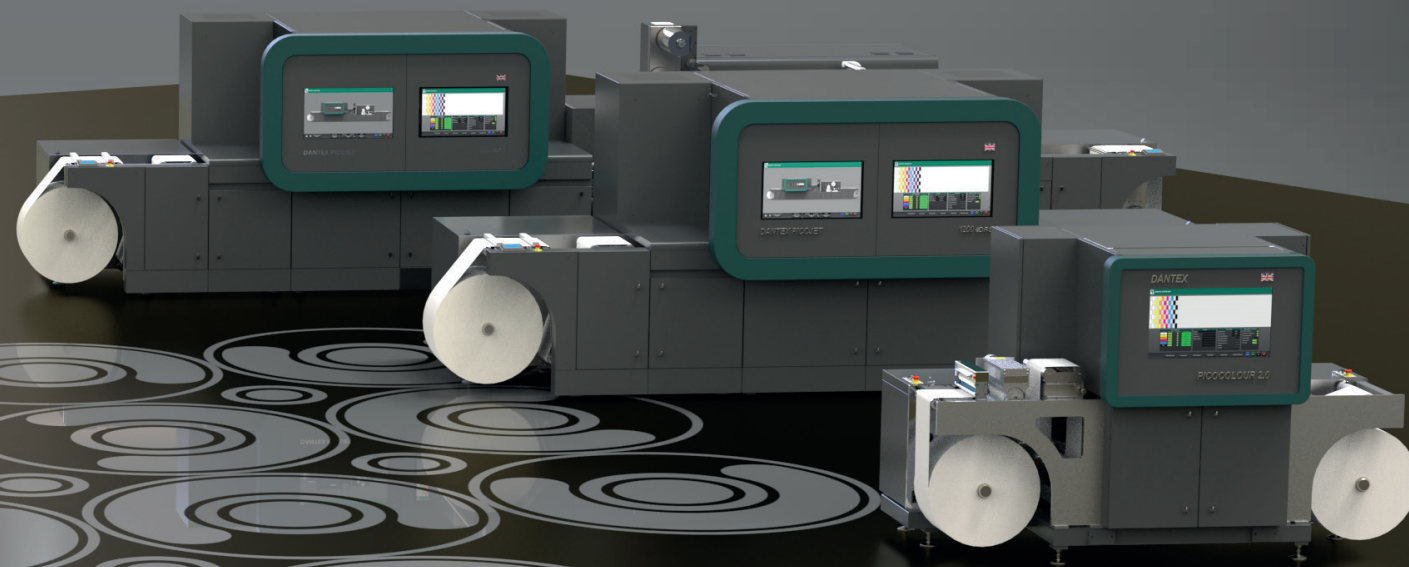

DANTEX
GROUP

PICO *DRS* TECHNOLOGY



EVOLVED & UNBEATABLE

Dantex Group has served the global label print and packaging industry for over 50 years. Our product portfolio includes a complete range UV Digital Label Presses under the brand of Pico, as well as letterpress and flexographic consumables and equipment. Dantex builds long-term customer relationships by bringing quality products and cost-effective solutions to the market.

Dantex's wealth of industry knowledge enables us to manufacture our own products because we understand customer requirements.

- Improve profitability on every label.
- Ultimate flexibility and highest print speeds available.
- Vivid, photo-realistic images and SuperWhite.
- Industry-leading software.
- No minimum print quantity.

Our increased presence in the global digital print market has led to the expansion of the Dantex Digital Division, which is based at our state-of-the-art production and Research & Development facility in the UK. The impressive Pico range of Digital UV Inkjet Presses offers print platforms from entry level to full hybrid, 8-colour, high-speed models.

The Pico Range: *PicoColour* and *PicoJet 1200 DRS* high resolution model. We offer solutions to suit individual production requirements.

- No speciality substrates or pre-coating required.
- A wide range of embellishments and finishing options.
- Super-fast job turnaround.
- Built to the highest quality industry standards.
- **DRS Technology: 1200, 1700, 2400 - The choice is yours!**

Dantex PicoJet 1200 with DRS Technology

- ✓ 8 Grey Levels
- ✓ Advanced Variable Dot Technology
- ✓ SuperText
- ✓ Superior print quality
- ✓ SuperText with Fine Lines
- ✓ High-Density Consistent Solids
- ✓ Smooth Gradients

Whether you're considering digital for short run, long run, or both, with **Pico by Dantex** you can have a highly productive, affordable label printing solution to meet your demanding production requirements, both now and in the future. **No minimum quantity, no speciality substrates, no pre-coating and super-fast turnaround - with superb quality results.**



VIEW THE FULL RANGE HERE:

LABEL PRODUCTION HAS NEVER BEEN SO EASY!

DRS
HEAD
TECHNOLOGY

TOUCH-SCREEN OPERATION

1200, 1700,
2400 DPI

SEMI OR FULL
ROTARY DIE
CUTTING

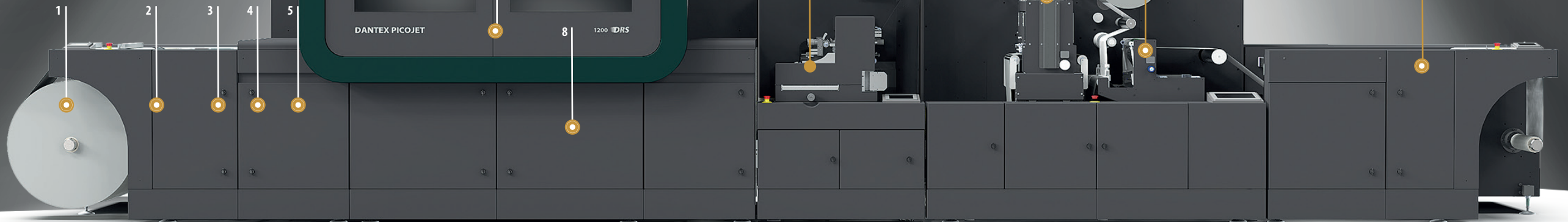

PICOJET 1200 DRS is A TRUE HYBRID SYSTEM, built on a modular platform it is available as a reel to reel press or bespoke hybrid system: a variety of base and additional colour stations can be custom configured to incorporate features such as full or semi rotary die cutting and a variety of flexo station options.

- 1 Unwind with automatic end of reel detection.
- 2 Automatic splice detection.
- 3 Web tracking system.
- 4 Web cleaner.
- 5 Corona unit.

- 6 32" machine operation HMI (PicoCenta)
- 7 32" control centre (PicoPilot)
- 8 Full LED final cure.
- 9 MADE IN BRITAIN.
- 10 Flexo station with LED or Mercury Arc curing.

- 11 Cold foiling/lamination.
- 12 Self-wound lamination. *(Not shown)*
- 13 Full rotary/Semi rotary die cutting options.
- 14 Edge trim
- 15 Rewind with tension compensation technology.

PICO TECHNOLOGY: SPECIFICATIONS



PICOJET 1200 DRS Reel-Reel model shown



PICO COLOUR Reel to Reel model shown

**NEW
PICO COLOUR**

- NOW WITH:
- Touch-screen operation

PICOJET 1200 DRS

PICOJET is built on a modular platform, so is available as a reel to reel press or as a bespoke hybrid system: allowing the incorporation of features such as Die Cutting and Flexo Station options. It can also be custom configured in a variety of base and additional colour stations.

- | | | |
|---|--|--|
| <ul style="list-style-type: none"> ● SYSTEM OPTIONS ● Additional Colour Stations ● SuperWhite® Station ● Corona ● Variable Data ● Mark Sensor ● Chilled Roller ● Reel Lifter ● Video Inspection System | <ul style="list-style-type: none"> ● DIE STATION OPTIONS ● Full Rotary / Semi Rotary ● Razor Slit / Shear Slit ● RD Scorer (Edge Trim) ● Self-wound Lamination ● Nip & Peel (<i>only with rewind</i>) ● Die Loading Trolley ● Die Cylinder Bench | <ul style="list-style-type: none"> ● FLEXO STATION OPTIONS ● LED Curing ● Mercury Arc Curing ● Cold Foil ● Lamination |
|---|--|--|

Print Width: 254mm / 10" (PJ1200), up to 350mm / 13.75"
Print Speed: 50m / 164' per minute, 75m / 250' per minute
Substrate Thickness: 50 - 300µm (*Thickness dependent on material properties*)
Available Colours: CMYK / WHITE / ORANGE / GREEN / VIOLET

PICO COLOUR

PicoColour is built on the PicoJet platform and benefits from this advanced technology and offers a print width of 254mm/10" and speeds up to 50m/164' per minute. PicoColour is available as CMYK or CMYK+White with compact inline finishing. Offering excellent printed results and suitable for short to long run jobs, this press provides all the benefits of digital printing for today's demanding production environment.

- | | | |
|--|---|--|
| <ul style="list-style-type: none"> ● SYSTEM OPTIONS ● SuperWhite® Station ● Corona ● Variable Data ● Mark Sensor ● Reel Lifter | <ul style="list-style-type: none"> ● FINISHING OPTIONS ● Die Cutting ● Slit/Edge (Razor) ● Lamination | <p>Print Width / Speed: 254mm / 10"
50m / 164' per min.</p> <p>Substrate Thickness: 50 - 300µm
<i>(Thickness dependent on material properties)</i></p> <p>Available Colours: CMYK / WHITE</p> |
|--|---|--|

ONE: DANTEX DRS HEAD TECHNOLOGY

DANTEX *DRS* HEAD TECHNOLOGY POWERED BY RICOH - 2400 DPI

Dantex Pico range uses Ricoh print heads with next generation jetting technology, which give an outstanding print result at high speeds. The Ricoh print heads produce truly striking photo-realistic print to suit all areas and applications of the label and packaging market. PicoJet is now available with our new DRS (Digital Resolution System) technology - **exceptionally high resolution or over 2400 dpi, developed in partnership and powered by Ricoh.**

Dantex's flagship press, PicoJet 1200, is capable of printing at speeds of up to 75m/min. In order to ensure our print head technology is running at 100% output at any speed, Dantex's engineers have developed a climate-controlled electronics system to ensure there is no over-heating or requirement for extraction fans; this keeps the print environment as clean and energy efficient as possible.

STANDARD 2 GREY LEVELS



STANDARD 4 GREY LEVELS

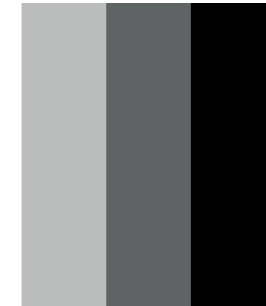

ENHANCED 8 GREY LEVELS (*DRS*)

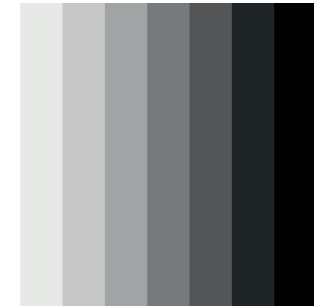

- DANTEX DRS - POWERED BY RICOH
- DRS (Digital Resolution System)
- 1700 - 2400 dpi
- High-speed Drop Accuracy.
- Higher Density solids.
- 2.5pl - 21pl drop size.
- 100% defect-free nozzle technology.
- Low contaminate print zone.
- Climate-controlled electronics.

Ricoh heads are manufactured with a high durability stainless steel housing giving outstanding reliability and stability at high speeds achieving superb, photo-realistic images. The Ricoh print heads' straight-forward alignment method allows high-precision positioning and registration.

The efficient high speed jetting technology allows the production of the same label at 75m/min. as at 20m/min.

VIEW THE FULL RANGE HERE:



TWO: SUPERTEXT TECHNOLOGY

SUPERTEXT TECHNOLOGY FROM DANTEX

Dantex has added a new fine text capability, SuperText®, to its PicoJet range. The impressive DRS UV digital press series offers a multitude of technically advanced features. The inclusion of SuperText, along with Dantex's SuperWhite® and SuperTactile® technologies, serve to create an unmatched end-to-end capability, whilst maintaining optimum quality and performance even at high speeds.

SuperText technology has been made possible by elevating the Pico's software and engineering capabilities, alongside the development of superior screening technologies and combining it with Dantex's high level Digital Front End, allowing for fine-line adjustments. This combination gives PicoJet the edge on fine text printing whilst maintaining optimum solid densities.

- Fine text printing.
- 2 point text achievable.
- Pharmaceutical approved.
- Sharpe edging on fine text.
- SuperTactile® compatible.
- SuperWhite® compatible.
- Superior screening technology.
- Optimal quality and performance.
- Even at high speeds.



VIEW THE FULL RANGE HERE: 

THREE: SUPERWHITE & DECOTACTILE

SUPERWHITE® & SUPERTACTILE SINGLE PASS, HIGH OPACITY

The Pico range features SuperWhite® technology which is capable of producing a white ink opacity up to 92% in a single pass, making it the highest opacity inkjet white available on the market, similar to that achieved printing with flat or rotary screen technology. This is achieved without any loss in print speed up to 75m (250ft)/min.

SuperWhite led to the development of SuperTactile®, which is used to create a range of high-quality embellishments to give enhanced detail and vibrancy, such as raised tactile finishes and textures. High-build capabilities to give a digitally embossed effect to chosen parts of the design, offering luxury finishes at low cost.

- Highest opacity inkjet white available.
- Single pass.
- Up to 92% opacity @ 75m/min.
- High quality bright white.
- Defined stable dot shape.
- No colour inter-mixing.
- Luxury finishes.
- DecoTactile print effects.
- No loss of speed.



Dantex's specially formulated white ink is instrumental to the quality of SuperWhite and DecoTactile finishes. Our curing technology stops the ink droplet from spreading and gives a defined dot shape, and superior quality printing of solid areas. This additionally improves fine white text, linework and reversed-out solids with no trapping or reticulation issues.



VIEW THE FULL RANGE HERE:



FOUR: ORANGE VIOLET & GREEN

ORANGE, VIOLET & GREEN ADDITIONAL COLOURS

The Pico range now offers 3 new additional colour options: Orange, Violet & Green. Our Pico press range is now capable of an extended colour gamut:

99% Colour Gamut @ Delta E of 3 and 97% @ Delta E of 2

Quality and accuracy are further enhanced in addition to greater colour matching capabilities. The extended gamut offers photo-realistic imagery with no loss of speed. Dantex's bespoke inkset allows our pinning technology to perform to its very best without needing to coat or prime material.

- 3 optional additional colours.
- 99% Pantone® range achievable
- No loss of speed.
- Excellent print quality.
- Excellent colour accuracy.
- Photo-realistic images.
- Future-proofing additional colours.
- SuperTactile® print effects.
- Bespoke colour profiling.



Dantex has partnered with industry leading software developers to maximize the efficiency and quality of the extended colour options. This extended range will help you to produce truly exquisite photo realistic labels day in, day out, with scientifically accurate pantones.

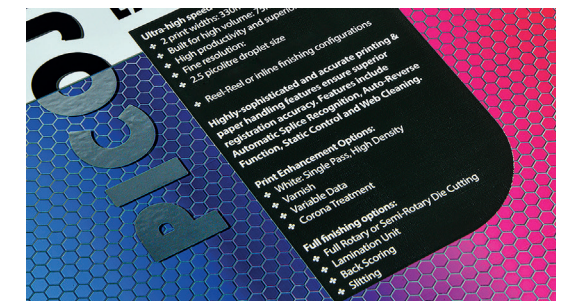

VIEW THE FULL RANGE HERE:



FIVE: COLOUR MANAGEMENT

COLOUR MANAGEMENT OPTIMAL PRINT QUALITY

Pico's software capabilities are enhanced through the integration of GIS (Global Inkjet Systems) & Esko's turnkey software solutions. Esko's DFE (Digital Front-end) together with our DRS technology enhances digital print for packaging making this the complete solution from print job creation to the optimisation of print quality through precise print head control.

Esko DFE software is easy to use, efficient and features systems which control the flow of jobs through the Esko DFE components and stores parameters and configurations. Combined with GIS fast screening technologies and GIS Atlas IQ® Tools for image quality control with print head density compensation, resulting in a seamless end-to-end solution.

- Esko's DFE (Digital Front-end)
- Easy to use and efficient.
- Precise print head control.
- Controlled job flow.
- Stores parameters & configurations.
- Edit Pantones.
- Create bespoke colours.
- Easy use step and repeat function.
- Full colour VDP.



Esko's DFE software allows the user to see the process colour values of any given pantone, which can be altered by as little as 0.1%. These values can be used to generate a colour chart which highlights many different iterations of the same pantone allowing the user to either select the lowest DE, or generate a customer approved bespoke colour.



VIEW THE FULL RANGE HERE:



SIX: INLINE FINISHING

INLINE FINISHING NOW WITH SEMI ROTARY DIE CUTTING

Every Pico press in the range is available as a reel-to-reel printing platform allowing you to utilise existing offline finishing systems, or they can be designed in a variety of hybrid configurations to maximize output and take your production capabilities to the next level.

Inline flexo options offer a multitude of embellishments from spot and flood coat varnishing to spot colours and cold foiling. Self-wound and pre-wound laminates can be applied, and the full or new semi rotary die station, along with edge trim and slit modules, means you can have applicator-ready labels coming off the PicoJet every day of the week. Print-to-cut registration in just one rotation with no station movement or mechanical setup required plus adjustable repeat lengths from 2" - 21"; line speeds up to 75m/min. ensures accurate processing over a wide range of substrates.

- Pre and Post print flexo stations.
- LED and ARC cure options.
- Full rotary/Semi-rotary die options.
- Easy load die trolley system.
- Easy web access and maintenance.
- Pre and self wound lamination.
- Varnish finishing options.
- Razor and shear slit options.
- Cold foiling and embellishments.



Our operator friendly presses offer all the features you need to produce a wide range of bespoke labels at high speeds. Achievable finishes include: soft & rough touch spot varnish, gloss & matte finishes, tactile effects, foiling, spot colours, self and pre-wound laminates. You can also run pre-printed materials, all finished with inline rotary or semi rotary die cutting and slitting.

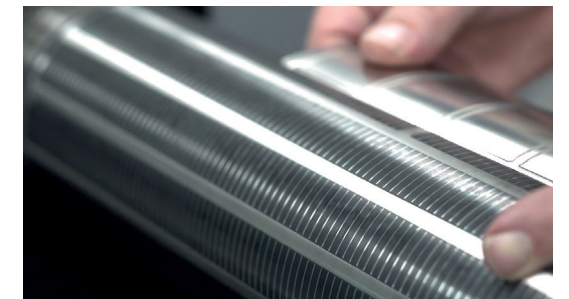

VIEW THE FULL RANGE HERE: 

SEVEN: LED CURE & PINNING

LED CURE INTER-COLOUR PINNING/FINAL CURE

LED UV curing is an ideal solution for the UV digital inkjet market. Dantex's innovative intercolour pinning technology stabilises ink efficiently, increasing print quality. Although ink spread can be prevented on any substrate, the user can also adjust intercolour pinning intensity to control the amount of ink absorption on particularly susceptible substrates. This pinning intensity control offers the added benefit of managing gloss/matte effect to give the desired result. Additionally, standard corona treatment prior to print allows the ink to adhere efficiently without loss of detail or quality and helps to prevent the mixing of wet inks. Overall, this allows for perfect colour matching through total control and stability and produces perfect results every time.

With final cure LED lamps, the intensity output of the LED lamp is better suited for through cure of thick ink films. Press speeds of 75m/min are achievable with the correct ink/LED combination. The lamps only turn on when the machine is printing and can be turned off in areas where there is no print present, for example when a narrower web is being used.

A UV LED lamp's life is around 20,000 hours, whereas the life of a traditional lamp is between 1000-2000 hours. With LED curing systems there is no ozone emitted from the lamp, meaning a safer environment for press operators. UV LED lamps emit minimal heat, so running more sensitive substrates is achievable. Because there is little heat and no ozone present, air ducting is not required resulting in a better working environment.

- Control of dot gain.
- Intensity (pinning) control.
- Reduced ink spread.
- Low voltage.
- High colour accuracy.
- Superb colour consistency.
- Low heat impact.
- Eco friendly.
- Fully adjustable.



UV cured ink has long been attractive to printers because of its near-instant drying and excellent adhesion properties to a wide range of substrates. In addition, it is more environmentally beneficial than other ink formulations, especially due to its low volatile organic compounds (VOC).

VIEW THE FULL RANGE HERE: 

EIGHT: WASTE REDUCTION

WASTE REDUCTION NOW WITH INSPECTION SYSTEMS

Dantex has an open platform for the integration of camera and inspection systems to suit the customer's requirements from the implementation of basic static or scanning devices through to full web inspection systems.

Pico offers a number of waste reduction features as standard; automatic splice detection ensures that the print heads are protected if there is a splice or mill join in the material by raising the print deck and letting a minimal amount of material through before print continuation.

Reverse function allows the reversing of material to the previous job's final print before continuing to the next job, giving virtually zero wasted material. Material profiling allows registration settings to be saved giving a quick, efficient material change with minimal set up, saving time and material.

- Camera and Full Inspection Systems.
- Automatic Splice Detection.
- Substrate reverse function.
- Automatic end of reel detection.
- Quick register adjustment.
- Pre-stored material settings.
- Ink saving profiles.
- Change ink on the run.
- Knight Guard software.



Dantex has developed ink saving colour profiles to use the bare minimum amount of ink necessary to produce excellent quality work.

Our **Knight Guard** software keeps the print heads active and optimized without constant purging and our proprietary inks are supplied and dispensed in a way that ensure you can use every last drop.



VIEW THE FULL RANGE HERE: 

NINE:
MADE
IN BRITAIN

MADE IN BRITAIN MANUFACTURING EXCELLENCE

Dantex is extremely proud to have passed a stringent 150 point requirements list which guarantees that our manufacturing supply chain is 'truly British'. Only those products that pass this test are permitted to carry the MADE IN BRITAIN mark. Being the ultimate mark of British provenance, the Made in Britain accreditation is seen as an international seal of excellence domestically and across the world.

On account of its rapid growth, our digital division recently moved to a new 22,000 square foot manufacturing site in the UK. From this facility, our digital division's highly skilled workforce undertakes research and development, design, assembly, build and shipping; thereby providing customers with the benefits of a closeness in British manufacturing and engineering to the very highest standards.

- Guaranteed quality.
- Reliable local supply chain.
- Highly skilled workers.
- High quality standards.
- New manufacturing facility.
- Investing in the future.
- Rapid growth.
- In house Research & Development.
- MADE IN BRITAIN.



MANUFACTURED IN THE UK

Pico Digital Presses are manufactured in our new and much larger facility in the UK. Our main demonstration center is also located in the UK and has been fitted with the latest in remote technologies so we can provide remote or live demonstrations for customers from all over the world.



VIEW THE FULL RANGE HERE:



TEN:
GET IN
TOUCH

DANTEX GROUP A TRULY GLOBAL PRESENCE

Dantex has been in the print and packaging for over 50 years, in this time we have built a reputation as one of the leading suppliers of printing equipment and consumables in the world. No matter where your company is based we have a subsidiary or distributor who are more than happy to help you with your digital printing needs. Please visit DANTEX.COM to register your interest and one of our highly-trained staff will contact you as soon as possible.

We thank you for your interest in our company and products and look forward to hearing from you soon.

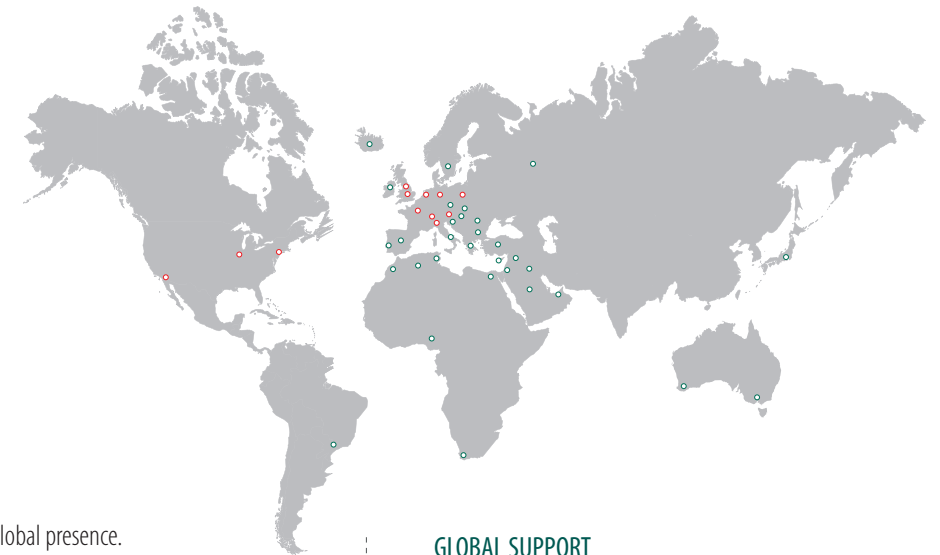

- Global presence.
- 2 Manufacturing sites in the UK.
- UK, US and German warehousing.
- Global distribution network.
- Sales and technical teams.
- Unbeatable customer service.
- Highly trained engineers and technicians.
- European demonstration facilities.
- Multilingual support.

GLOBAL SUPPORT

Pico Digital Presses are manufactured in our facility in the UK and we have customer demonstration facilities in the UK and Europe. Our warehousing is located in the UK, US and Germany enabling us to provide quick and efficient technical support, as well as parts and goods shipment.